

Traillex

SPORT UTILITY TRAILERS

SUT-500-S

500 LB. CAPACITY

TRAILER

Assembly Instructions

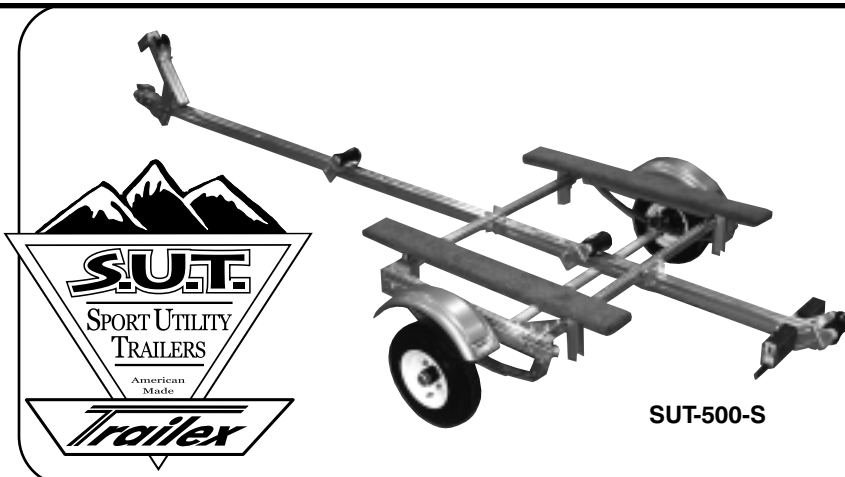

ASSEMBLY REQUIREMENTS

- ✓ Torque all "T" bolt nuts to 38-40 foot pounds.
- ✓ Check all lights before towing
- ✓ Tire pressure not to exceed sidewall recommendation.
- ✓ Re-Torque wheel nuts after first 25 miles to 80 ft. pounds and periodically thereafter.

STEP 1

SUGGESTED TOOLS

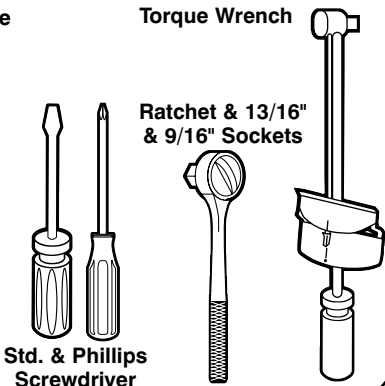
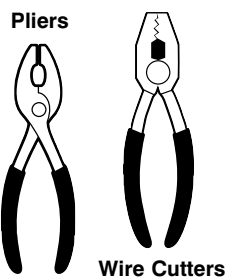

STEP 2

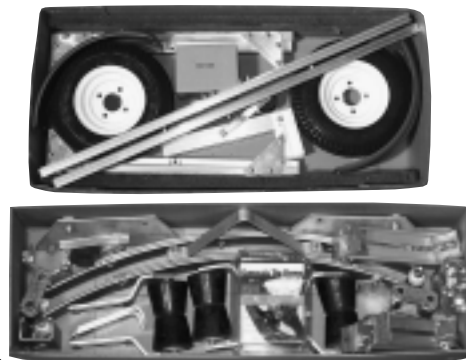

- ❑ Remove and Identify all parts from boxes. (Refer to exploded drawing parts list).
- ❑ Layout all parts to configuration of trailer using assembly sheet as your guide.



STEP 3

- ❑ Layout square frame as (Shown in A). Slide front and rear crossmembers under triangle plates (attached to side rails). Using "T" bolt heads supplied. Snug nuts on top of triangle plates front and rear. Repeat process on other side rail. Square frame and tighten all nuts on triangle plates.
- ❑ Attach assembled square to tongue section with 4 brackets and "T" bolts. Set rear of tongue section to rear of square frame approximately 28". (Shown in A & C).
- ❑ Attach front and center 6" roll (Shown in C). Final adjustment will occur when boat is loaded on trailer. Front and center 6" roll should support hull when boat is loaded. (Rear roll assembly should not touch hull, for easy loading only).

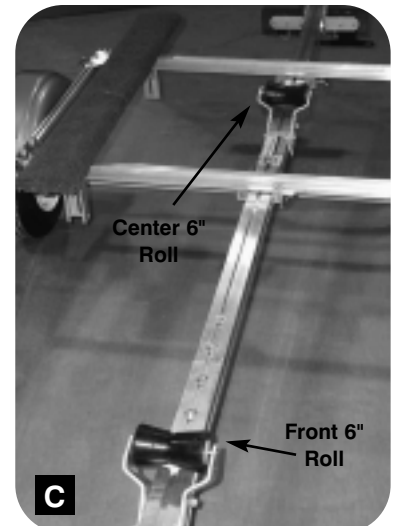
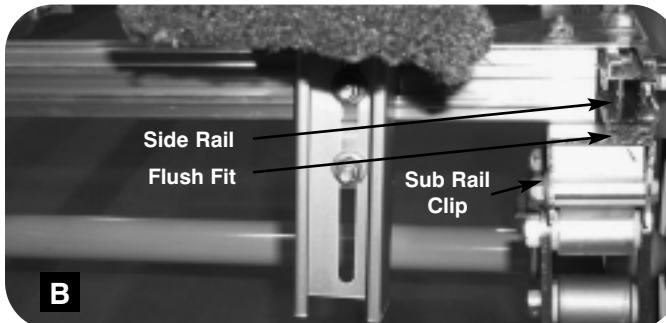
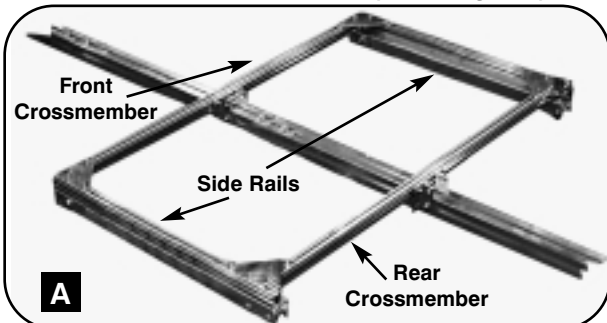

STEP 4

- ❑ Attach 4 bunk brackets (Shown in D)(Slot is for adjustment). Then lay bunks down with bolt attached, carpet faces upward. Put lock washer first then tighten nut (Shown in D & E). Final adjustment of bunks will occur when boat is loaded on trailer.
- ❑ Attach fenders (Shown in F) this order - 1) Large rubber washer, 2) Steel washer 3) Fender, 4) Steel washer, 5) Flanged lock nut. DO NOT TIGHTEN BOLTS AT THIS TIME. Wait until axle and wheels are on then center fenders over tires and tighten.

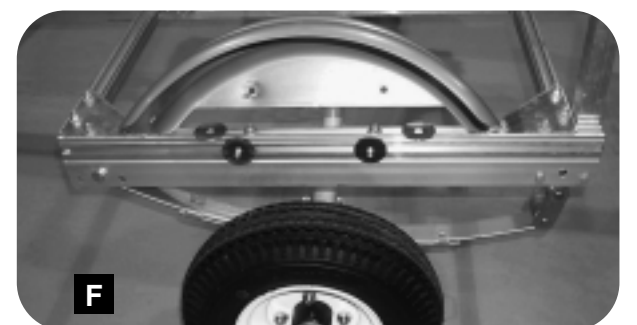
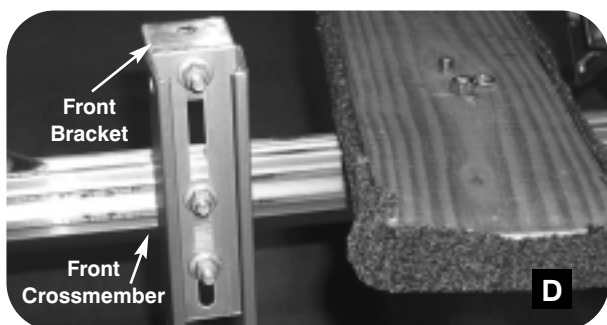

STEP 5

- ❑ Install taillight brackets and rear 6" roll to rear of tongue. Secure taillight brackets in place (Shown in G). Final location of 6" rear roll assembly to be determined with boat in place (roll only meant for loading - - does not touch boat hull when in trailering position).
- ❑ Pull black tab and drop light bulb assembly out (Shown in H). This is how you will change the bulb when needed.
- ❑ After lights and brackets are installed, pull wiring harness through the tongue section, start at opening in front under the coupler and pull through to the rear opening (Shown in I). Attach the green-brown and yellow-brown wires to the color matching phillips screws in the taillights. (Green-Brown Right, Yellow-Brown Left standing behind trailer). Attach the white ground wire to one of the taillight bolts. (Shown in I).

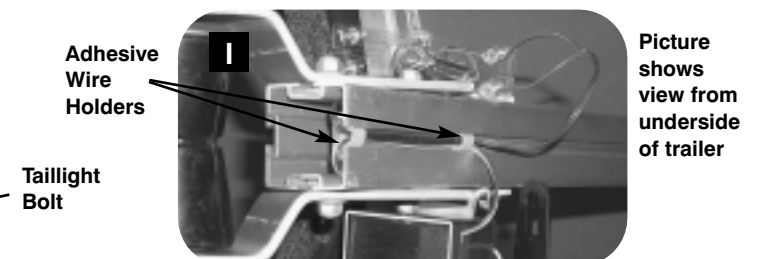
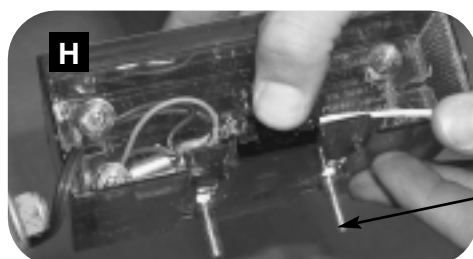

STEP 6

- Pull harness towards front, until taut. Take two yellow marker lights, strip white wires and secure them to the ring terminals (Shown in J).
- Secure yellow side marker lights and white wires with ring terminals to mounting bracket with screws provided (Check that you do not pinch brown wire between marker light and bracket)(Shown in J).
- Go to inset instructions below (Shown in K).
- Attach tongue skid straddling yellow lights and bracket. Attach white ground wire to screw under front of tongue.

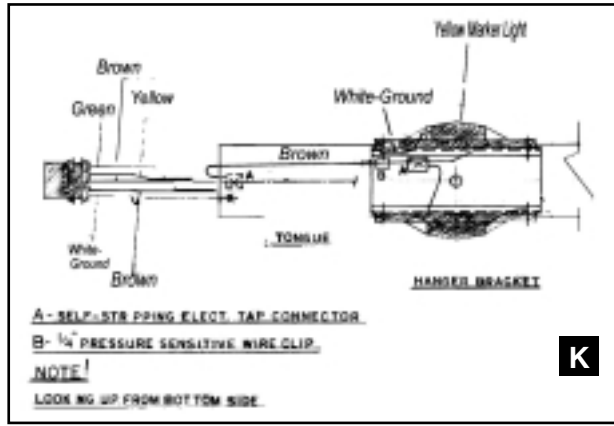
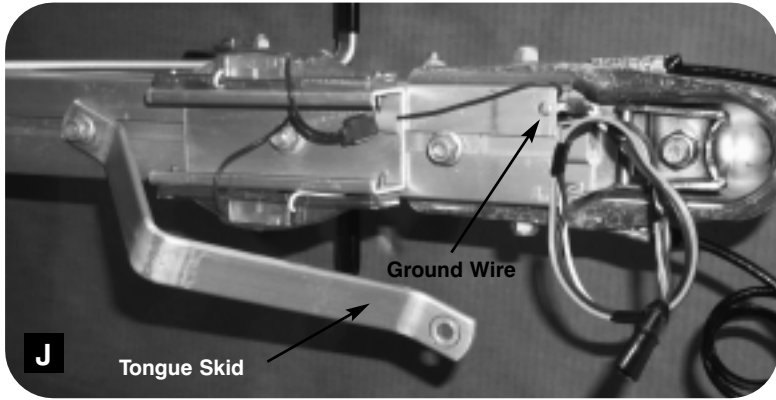

- Using (2) blue wire connectors on brown wire of wire harness, then connect with brown wire from yellow side marker lights. See SKETCH. Use pliers to make permanent connection.

STEP 7

- Attach spring to sub rail, using center hole (Shown in picture L). All bolts face inward with nuts on the inside of trailer. (Go to inset for detail). Attach shackle to spring, push shackle with bolts attached towards inside of trailer. Then push shackle plate on shackle bolts, then tighten nuts (Do not over tighten nuts - leave motion in shackle).
- Lay axle on spring (Shown in picture M) take two U-Bolts, 1 Plate, 4 Lock Nuts - surround axle pushing downward. Tighten U-Bolt nuts to 80 foot pounds.
- TEST: With trailer assembled on ground put pressure on trailer frame and observe movement in spring shackle, spring and axle. If shackle stays firm-loosen counter clockwise 1/4" turn - until shackles move.

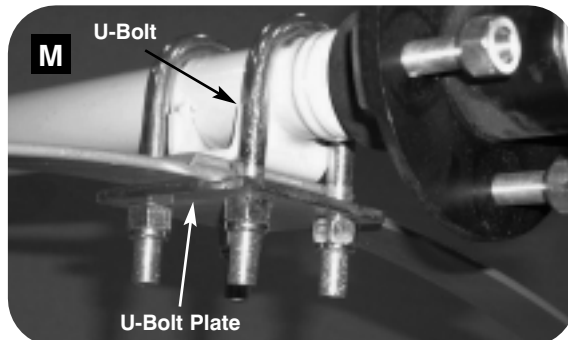
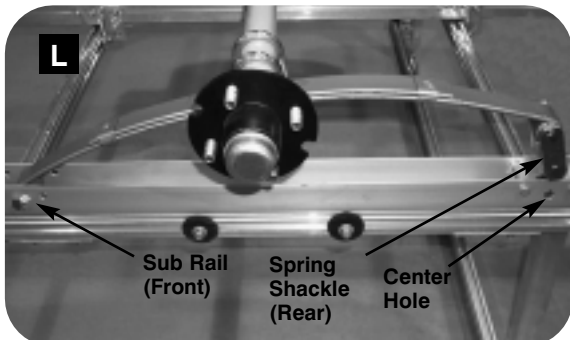

STEP 8

- Put Boat on trailer, make sure left and right bunks are supporting hull. Adjust front and center roll, they will support hull. Adjust bow stand and rear 6" roll assembly (Rear roll should not touch boat, for easy loading only).
- Install tires on hubs using 13/16" socket and ratchet (torque to 80 ft. pounds, re-torque after first 25 miles).
- Front mast stand with winch cap. Adjustable for boat - drill cap for winch later.
- Secure boat to trailer, check coupler hook up, lights and begin towing!

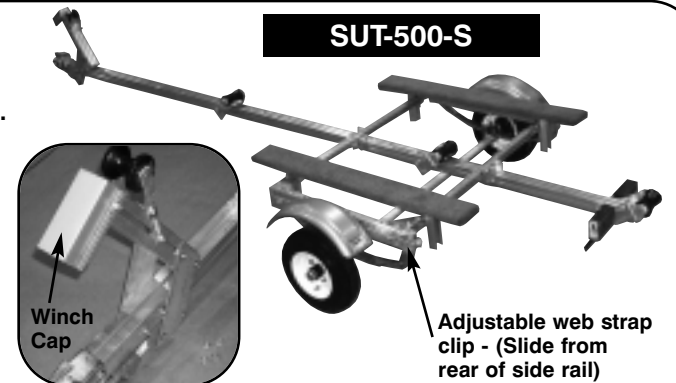

Other SUT Products Available - All Products are UPS-able

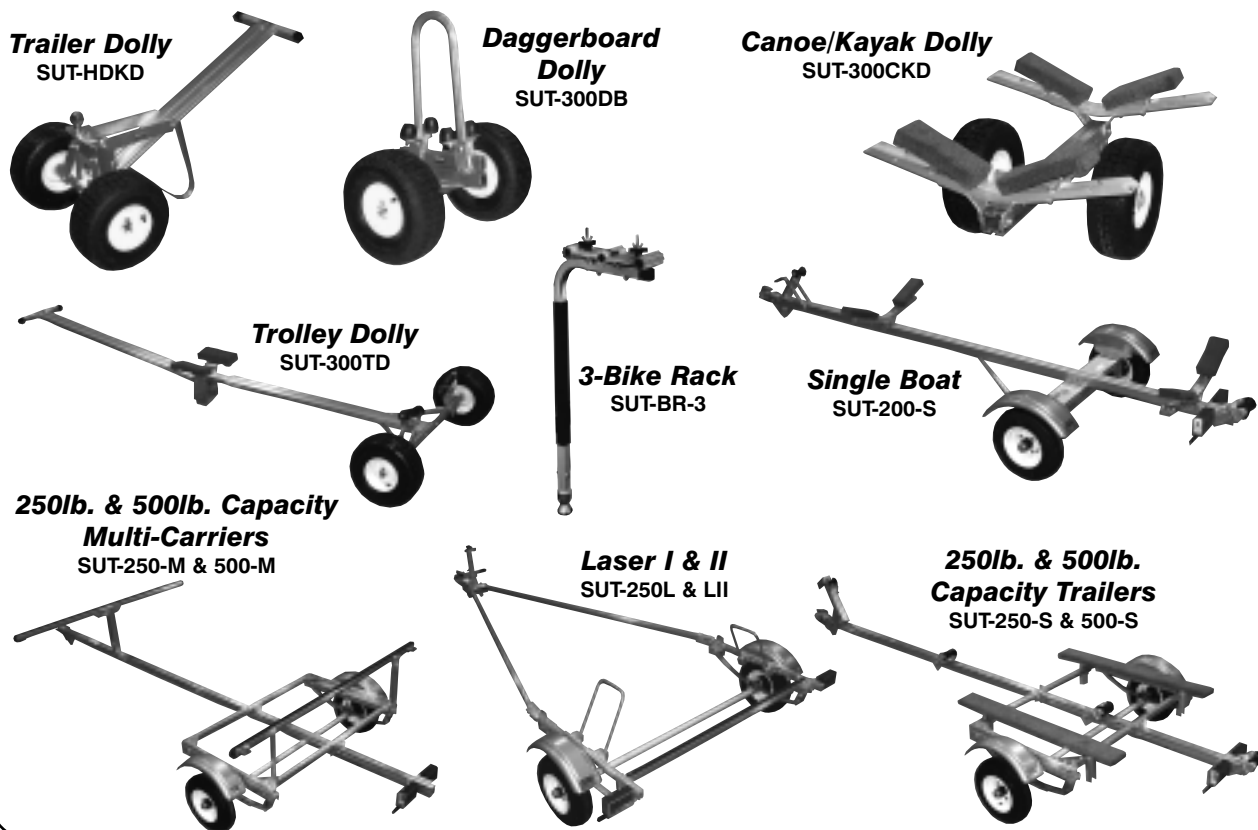

TRAILEX SUT PRODUCT LINE PRODUCT WARRANTY

Trailex Incorporated, 1 Industrial Park Drive, Canfield, OH 44406, states that this Warranty is designed and intended to fully comply with the requirements of Magnuson-Moss Warranty Act and all the Regulations issued by the Federal Trade Commission in connection therewith. It is not intended to violate any applicable State Law or Regulations containing more stringent requirements.

I. Duration
This warranty is given and extends for a period of one year (three hundred and sixty-five days) from date of original purchase. The implied Warranty of merchantability and fitness for particular purpose are limited to the duration of this Warranty - one year (three hundred and sixty-five days). After said one year (three hundred and sixty-five days), Trailex Incorporated expressly disclaims any Warranty of merchantability or fitness for any purpose.

II (A) Coverage
Trailex Incorporated warrants its products to be free of defects in material and workmanship under normal use and with reasonable care and maintenance, and under such conditions as set forth in this Warranty. Trailex Incorporated's obligation shall be limited to repairing or replacing defective parts at its factory at 1 Industrial Park Drive, Canfield, OH 44406, telephone number (330)533-6814, or at any authorized dealers. Any part or parts covered by this limited Warranty shall, within the one year (three hundred and sixty-five days) period hereinbefore specified, be returned to it with transportation prepaid and which, upon examination by Trailex Incorporated or an authorized dealer, show to have been defective. This Warranty extends to the original purchaser only and those protected by existing law and is not transferable.

III. Exclusions
This Warranty specifically does not cover:
(a) Expendable items including tires, cables, ropes, lines, brakes, tie downs, etc.
(b) Cost of repairs made other than by Trailex Incorporated or an authorized dealer.
(c) Products which shall have been repaired or altered by other than Trailex Incorporated or an authorized dealer.
(d) Products which shall have been subject to negligence or accidents or damage by circumstances beyond the company's control, or by improper operation, over-loading beyond stated capacity, maintenance or storage, or were used other than the normal use of service for which the trailer is intended.
(e) With respect to any component of the products covered by this Warranty which shall not be actually manufactured by Trailex Incorporated, the Warranty extended to the purchaser or claimant shall be limited to the Warranty extended by the manufacturer.
(f) Trailex Incorporated does not undertake responsibility to any purchaser of its products for any undertaking, representation or Warranty made by the dealers or third persons selling its product, beyond the Warranties herein expressed.
(g) Purchase of other acceptance of the products by any claimant under the Warranty provisions shall be on the condition and agreement that Trailex Incorporated shall, under no circumstances, be liable for any direct, indirect, consequential, contingent or incidental damage of any kind or nature whatsoever, including, but not limited to damage to any personal property or real property of the purchaser or others resulting from any breach of this limited one year (three hundred and sixty-five days) Warranty.
(h) Warranty voided if load equalizer type hitch is used.
(i) Warranty void if assembly instruction requirements are not precisely followed

IV. Claim Procedure:
To make claim under this Warranty, write or call directly to Trailex Incorporated, 60 Industrial Park Drive, Canfield, OH 44406, Telephone Number (330)533-6814, identifying the trailer by serial number and giving its location. The company will give instructions within the (10) days following receipt of said claim. Trailex Incorporated will exert its best effort to repair or replace the part or parts if found to be defective within the terms of this Warranty, within (60) days after notification of the claim. In addition to the provisions of this Warranty, the retail purchaser has available the legal remedies provided by the Magnuson-Moss Warranty Act, Public Law 93-627, 88 Stat. 2183-2193, U.S. Code, Secs. 2301-2312, and any applicable State statutes.
(j) Void if weight limit of vin tag is exceeded.

Warranty



P.O. Box 553 • 1 Industrial Park Dr.
Canfield, OH 44406-0553
Phone: (330) 533-6814
Fax: (330) 533-9118



SUT-500-S Trailer for boats up to 500 pounds, suited for a bunk trailer

Additional Trailers and information can be seen from our web site at: www.trailex.com

Made In U.S.A.

Trailex reserves the right to discontinue models at anytime, change price, specs, or design without notice and without obligation.